

N.b. ROD-EYE ORIENTATION NOT GUARANTEED.  
CONNECTORS; MICRO MINI WETMATE, 4-POLE.  
BULKHEAD; MCBH-4-MP-SS, STAINLESS STEEL/MOLDED NEOPRENE, SEALING; 340 BAR OPEN FACE, 600 BAR MATED.  
IN-LINE; MCIL-4-FS, MOLDED NEOPRENE WITH CABLE. LOCKING SLEEVE; MCDLS-F, DELRIN.

**ELECTRICAL OPTIONS/ SPECIFICATIONS**

OUTPUT	SUPPLY
0.5 TO 4.5V RATIO METRIC	5V
SUPPLY CURRENT 12mA TYP. 20mA MAX.	

MATING CONNECTOR (CODE 'J50' OR 'K50') SUPPLIED WITH 50cm MOULDED CABLE AS STANDARD.  
4-CORE SCREENED: 0.5mm<sup>2</sup>, Ø7.5mm MAX. JACKET AND CORE INSULATION: EPDM.

**CONNECTIONS:-**

1	BLACK	OUTPUT
2	WHITE	0V
3	RED	BODY
4	GREEN	+Ve
	SCREEN	NOT CONNECTED TO SENSOR

RANGE OF DISPLACEMENT FROM 0-5mm TO 0-800mm e.g.76mm, IN INCREMENTS OF 1mm.

BODY MATERIAL: STAINLESS STEEL 316.

**FURTHER OPTIONS:**

SINGLE PAIR OF BODY CLAMPS 'P'  
TWO PAIRS OF BODY CLAMPS 'P2'  
SPRING RETURN PUSH-ROD, TRAVEL ≤300mm  
RETURN TO EXTENDED POSITION (CODE R)  
RETURN TO RETRACTED POSITION (CODE S)  
PUSH-ROD FREE (CODE 'V') - NOT AVAILABLE WITH SPRUNG OPTIONS.

NOTE:- READ INSTALLATION SHEET G000-19 FOR FULL INSTRUCTIONS FOR USE.

CSA APPROVED TO  
Class I Zone 0  
Ex/AEx ia IIC T4 (Ta= -40 to 80°C)  
Ui 11.4V, Ii 0.2A, Pi 0.51W

APPROVED FOR USE IN CONJUNCTION WITH A GALVANICALLY ISOLATED BARRIER.

NOTE: APPROVAL ONLY APPLIES AT NORMAL ATMOSPHERIC PRESSURE!

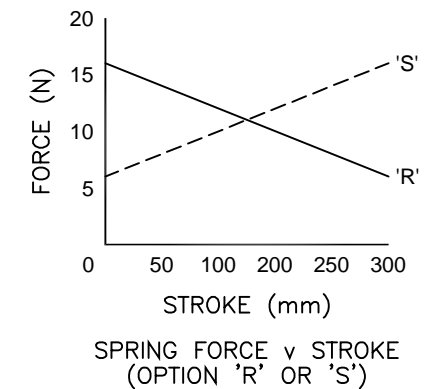
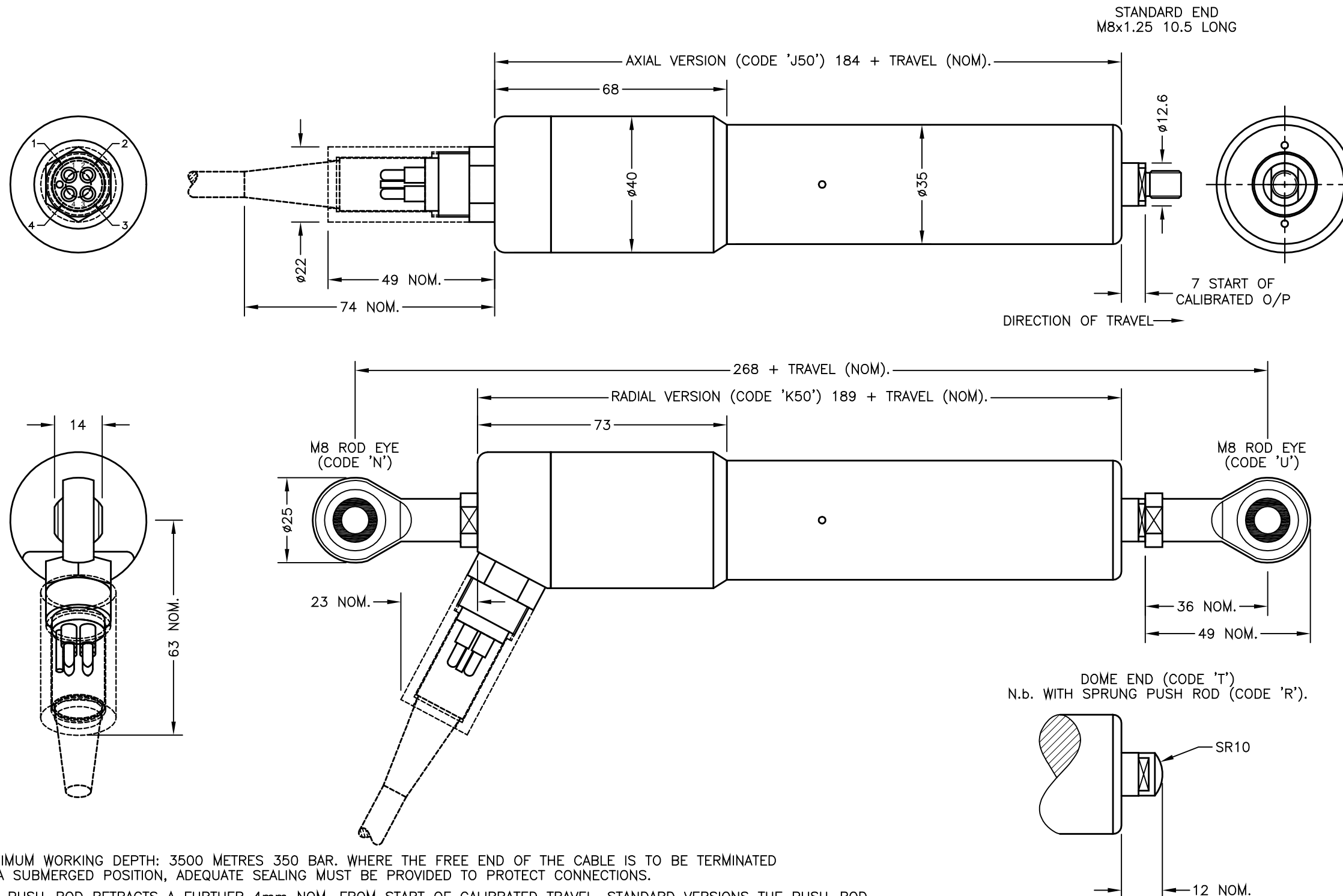

MAXIMUM WORKING DEPTH: 3500 METRES 350 BAR. WHERE THE FREE END OF THE CABLE IS TO BE TERMINATED IN A SUBMERGED POSITION, ADEQUATE SEALING MUST BE PROVIDED TO PROTECT CONNECTIONS.

THE PUSH-ROD RETRACTS A FURTHER 4mm NOM. FROM START OF CALIBRATED TRAVEL. STANDARD VERSIONS THE PUSH-ROD EXTENDS A FURTHER 8mm NOM. FROM END OF CALIBRATED TRAVEL, FOR SPRUNG VERSIONS: 'R': 1mm, 'S': 2mm. 'V' CODED PUSH-ROD WILL DEPART SENSOR BODY.

A	FIRST ISSUE	RDS
B	OMITTED OPTIONS ADDED.	PDM
C	"7 START OF..." WAS "7.00 START OF...".	PDM
D	MALE M8 WAS FEMALE RAN1180	RDS
E	CABLE COLOURS CORRECTED - RAN1190	PDM
F	3500 METERS WAS 3482 RAN1145	RDS
G	RANGE NOTE AMENDED ~ RAN1200	PDM



DRAWINGS NOT TO BE CHANGED WITHOUT REFERENCE TO THE CHANGE PROCEDURE. CHANGES TO PARTS USED IN INTRINSICALLY SAFE PRODUCT MUST BE APPROVED BY THE AUTHORISED PERSON  
THIS IS AN UNCONTROLLED PRINT AND WILL NOT BE UPDATED.

**POSITEK**  
  
**LIMITED**

A	24/09/15		CHECKED BY	X	±0.4
B	08/01/16		RDS	X.X	±0.2
C	21/10/16			X.XX	±0.1
					DIMS mm
D	25/4/17	DESCRIPTION			
E	14/06/17	INTRINSICALLY SAFE 350 BAR			
F	15/06/17	SUBMERSIBLE STAND-ALONE			
G	12/09/17	LINEAR POSITION SENSOR			
SCALE		DRAWING NUMBER		REV	
12.5mm		G125-11		G	
		SHEET		1 OF 1	



# G125 350 BAR SUBMERSIBLE STAND-ALONE LINEAR POSITION SENSOR INTRINSICALLY SAFE FOR HAZARDOUS GAS/VAPOUR ATMOSPHERES

- **Intrinsically safe for Gas to:  
Class I, Zone 0 Ex ia / AEx ia  
Class 1 Division 1**
- **Travel set to customer's requirement**
- **Compact and self-contained**
- **High durability and reliability**
- **High accuracy and stability**
- **Sealing to IP68 350Bar**



As a leading designer and manufacturer of linear, rotary, tilt and intrinsically safe position sensors, Positek® has the expertise to supply a sensor to suit a wide variety of applications. Our G125 incorporates electronics system EX08 which is CSA approved for use in potentially explosive **gas/vapour** atmospheres. The G125 is designed to provide feedback for arduous underwater applications, such as ROVs, where hazardous surface conditions may exist. It remains an affordable, durable, high-accuracy position. The unit is highly compact and space-efficient, being responsive along almost its entire length. Like all Positek® sensors, the G125 provides a linear output proportional to displacement. Each sensor is supplied with the output calibrated to the travel required by the customer, from 5 to 800mm and with full EMC protection built in. The sensor is very robust, the body and push rod being made of stainless steel for long service life and environmental resistance. Overall performance, repeatability and stability are outstanding over a wide temperature range. The sensor is easy to install with mounting options including M8 rod eye bearings and body clamps. The push rod can be supplied free or captive with male M8 thread, an M8 rod eye, dome end or magnetic tip. M12 and 1/2" rod eye options available. Captive push rods can be sprung loaded, in either direction, on sensors up to 300mm of travel. The G125 also offers a range of mechanical options, environmental sealing is to IP68 350 Bar.

## SPECIFICATION

<b>Dimensions</b>	
Body diameter	40 mm electronics & 35 mm
Body length (Axial version)	measurement length + 184 mm
Body length (Radial version)	measurement length + 189 mm
Push rod extension	measurement length + 7 mm, OD 12.6 mm
<i>For full mechanical details see drawing G125-11</i>	
<b>Independent Linearity</b>	$\leq \pm 0.25\%$ FSO @ 20°C - up to 450 mm $\leq \pm 0.5\%$ FSO @ 20°C - over 450 mm
<b>Temperature Coefficients</b>	$< \pm 0.01\%/^{\circ}\text{C}$ Gain & $< \pm 0.01\%$ FS/ $^{\circ}\text{C}$ Offset > 10 kHz (-3dB)
<b>Frequency Response</b>	Infinite
<b>Resolution</b>	$< 0.02\%$ FSO
<b>Noise</b>	Class I, Zone 0
<b>Intrinsic Safety</b>	Ex ia IIC T4 Ga AEx ia IIC T4 Ga Class I, Division 1, Groups A, B, C, D; T4 (Ta = -40°C to +80°C)
Approval only applies to the specified ambient temperature range and atmospheric conditions in the range 0.80 to 1.10 Bar, oxygen $\leq 21\%$	
<b>Sensor Input Parameters</b>	Ui: 11.4V, Ii: 0.20A, Pi: 0.51W.
(without cable)	Ci: 1.16 $\mu\text{F}$ , Li: 50 $\mu\text{H}$
(with cable)	Ci: 1.36 $\mu\text{F}$ , Li: 860 $\mu\text{H}$ with 1km max. cable
<b>Environmental Temperature Limits</b> (Non Icing)	
Operating	-4°C to +50°C
Storage	-4°C to +50°C
<b>Sealing</b>	IP68 350Bar
<b>EMC Performance</b>	EN 61000-6-2, EN 61000-6-3
<b>Vibration</b>	IEC 68-2-6: 10 g
<b>Shock</b>	IEC 68-2-29: 40 g
<b>MTBF</b>	350,000 hrs 40°C Gf
<b>Drawing List</b>	
G125-11	Sensor Outline
3D models, step or .igs format, available on request.	

**Do you need a position sensor made to order to suit a particular installation requirement or specification? We'll be happy to modify any of our designs to suit your needs - please contact us with your requirements.**



For further information please contact:

[www.positek.com](http://www.positek.com) [sales@positek.com](mailto:sales@positek.com)

Tel: +44(0)1242 820027 fax: +44(0)1242 820615

Positek, Andoversford Industrial Estate, Cheltenham GL54 4LB. U.K.

G125-17j

1 of 3



# G125 350 BAR SUBMERSIBLE STAND-ALONE LINEAR POSITION SENSOR INTRINSICALLY SAFE FOR HAZARDOUS GAS/VAPOUR ATMOSPHERES

Intrinsically safe equipment is defined as "equipment which is incapable of releasing sufficient electrical or thermal energy under normal or abnormal conditions to cause ignition of a specific hazardous atmosphere mixture in its most easily ignited concentration."

CSA approved to;

Class I, Zone 0 Ex ia IIC T4 Ga AEx ia IIC T4 Ga  
Class I, Division 1, Groups A, B, C, D; T4  
(Ta = -40°C to +80°C)

Designates the sensor as belonging to; Class I, Zone 0: can be used in areas with continuous, long or frequent periods of exposure to hazardous gas / vapours.

Protection class ia IIC, denotes intrinsically safe for Zones 0, 1 & 2 and IIA, IIB and IIC explosive gases.

Temperature class T4: maximum sensor surface temperature under fault conditions 135°C.

Ambient temperature range extended to -40°C to +80°C.

It is imperative Positek® intrinsically safe sensors be used in conjunction with a galvanic barrier to meet the requirements of the product certification. The Positek G005 Galvanic Isolation Amplifier is purpose made for Positek IS sensors making it the perfect choice. Refer to the G005 datasheet for product specification and output configuration options.

For cable lengths exceeding 10 metres a five wire connection is recommended to eliminate errors introduced by cable resistance and associated temperature coefficients.

CSA approved sensors suitable for dust (H series) applications, are also available from Positek.

G125	a	b	c	d	e	f	g	h	j
	Displacement	A	Connections	Option	Option	Option	Option	Option	Z000

<p><b>a Displacement</b> <b>Value</b></p> <p>Factory set to any length from 0-5 mm to 0-800 mm (e.g. 0-254 mm) <b>254</b></p> <p><b>b Output</b></p> <table border="1"> <thead> <tr> <th>Supply <math>V_{dc}</math> (tolerance)</th> <th>Output</th> <th>Code</th> </tr> </thead> <tbody> <tr> <td>+5V (4.5 - 5.5V)</td> <td>0.5 - 4.5V (ratiometric with supply)</td> <td><b>A</b></td> </tr> </tbody> </table> <p>Supply Current 10mA typical, 12mA max.</p> <p><b>c Connections</b> <b>Code</b></p> <p>Connector axial IP68 350 Bar Wet mate 4 pin MC BH-4-M <b>J50</b></p> <p>Connector radial IP68 350 Bar Wet mate 4 pin MC BH-4-M <b>K50</b></p> <p>Supplied with an over-moulded MC IL-4-F connector with 0.5 m, 4-core 20 AWG (0.5mm<sup>2</sup>) EPDM cable assembly, and locking collar as standard.</p> <p><b>d Body Fittings</b> <b>Code</b></p> <p>None default blank</p> <p>M8 Rod-eye bearing radial version only <b>N</b></p> <p><b>e Body Clamps</b> <b>Code</b></p> <p>Body Clamps 1 pair <b>P</b></p> <p>Body Clamps 2 pairs <b>P2</b></p>	Supply $V_{dc}$ (tolerance)	Output	Code	+5V (4.5 - 5.5V)	0.5 - 4.5V (ratiometric with supply)	<b>A</b>	<p><b>f Sprung Push Rod</b> <b>Code</b></p> <p>Not sprung default blank</p> <p>Spring extend <b>R</b></p> <p>Spring retract <b>S</b></p> <p>300 mm maximum displacement and captive push rod only.</p> <p><b>g Push Rod Fittings</b> <b>Code</b></p> <p>Male thread M8x1.25x10 long default blank</p> <p>Dome end with spring extend option 'R' <b>T</b></p> <p>M8 Rod-eye Bearing <b>U</b></p> <p>Magnetic Tip <b>WA</b></p> <p><b>h Push Rod</b> <b>Code</b></p> <p>Captive push rod retained default blank</p> <p>Non-captive push rod can depart body <b>V</b></p> <p><b>j Z-code</b> <b>Code</b></p> <p>Calibration to suit G005 default <b>Z000</b></p> <p>Tighter Independent Linearity; <math>\leq \pm xx\%</math> FSO @20°C</p> <p><math>\leq \pm 0.1\%</math> 0 - 10 mm min. to 0 - 450 mm <b>Z650</b></p> <p><math>\leq \pm 0.25\%</math> 0 - 451 mm to 0 - 600 mm</p> <p><math>\leq \pm 0.5\%</math> 0 - 601 mm to 0- 800 mm max.</p> <p>1/2" Rod eyes with options 'N' and/or 'U' <b>Z825</b></p> <p>M12 Rod eyes with options 'N' and/or 'U' <b>Z826</b></p>
Supply $V_{dc}$ (tolerance)	Output	Code					
+5V (4.5 - 5.5V)	0.5 - 4.5V (ratiometric with supply)	<b>A</b>					

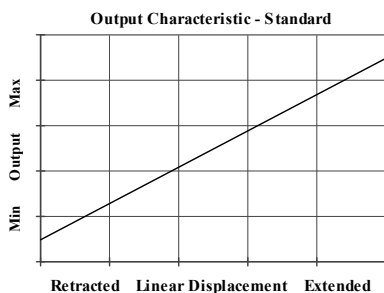

For further information please contact:

[www.positek.com](http://www.positek.com) [sales@positek.com](mailto:sales@positek.com)

Tel: +44(0)1242 820027 fax: +44(0)1242 820615

Positek, Andoversford Industrial Estate, Cheltenham GL54 4LB. U.K.

G125-17j



# Three or Five-Wire Mode Connection

## FOR INTRINSICALLY SAFE SENSORS IN HAZARDOUS ATMOSPHERES

The aim of this document is to help readers who do not understand what is meant by three or five wire modes of connection between the galvanic isolation amplifier and sensor, and the factors behind them. It is by no means an in-depth technical analysis of the subject.

Whether opting for a pre-wired Positek® Intrinsicly Safe sensor or one with a connector, choosing the right mode of connection and cable to suit the application requires careful consideration.

Interconnecting cables are not perfect conductors and offer resistance to current flow, the magnitude of resistance<sup>†</sup> depends on conductors resistivity, which changes with temperature, cross sectional area<sup>‡</sup> and length. If the voltage were to be measured at both ends of a length of wire it would be found they are different, this is known as volts drop. Volts drop changes with current flow and can be calculated using Ohm's law, it should be noted that volts drop occurs in both positive and negative conductors. The effects of volts drop can be reduced by increasing the conductors cross sectional area, this does not however eliminate the effects due to temperature variation. There are instances where large cross-section cables are not practical; for example most standard industrial connectors of the type used for sensors have a maximum conductor capacity of 0.75mm<sup>2</sup>, copper prices and ease of installation are other considerations.

This is important because the effects of volts drop can significantly alter the perceived accuracy of the sensor which is ratiometric i.e. the output signal is directly affected by the voltage across the sensor. Changes in temperature will also be seen as gain variation in the sensor output.

**Three wire mode** connections are common and are suitable in most cases with short or moderate cable runs. Applications that do not require a high degree of accuracy but have cable runs, say in excess of 10m, volts drop can be reduced by introducing a terminal box close to the sensor and using a larger cross-section cable for a majority of the cable run. Sensors supplied with three core cable are calibrated with the cable fitted which largely eliminates errors due to conductor resistance at room temperature however, as mentioned above, small gain errors due to temperature fluctuations should be expected.

**Five wire mode** connections have significant benefits as losses in the positive and negative conductors are compensated for by the galvanic isolation amplifier which can 'sense' the voltage across the sensor and dynamically adjust the output voltage so that the voltage across the sensor is correct. The effects of cable resistance and associated temperature coefficients are eliminated allowing for smaller conductors than a three wire connection for the same cable run. The amplifier can compensate for up to 15Ω per conductor with a current flow of 15mA, which is more than adequate for 150m of 0.25 mm<sup>2</sup> cable, longer lengths will require larger conductors.

**For this reason Positek® recommends five wire connections for cable lengths exceeding 10 metres in 0.25 mm<sup>2</sup> cable to preserve the full accuracy of the sensor.**

See illustrations below for examples of connecting a sensor to the galvanic isolation amplifier.

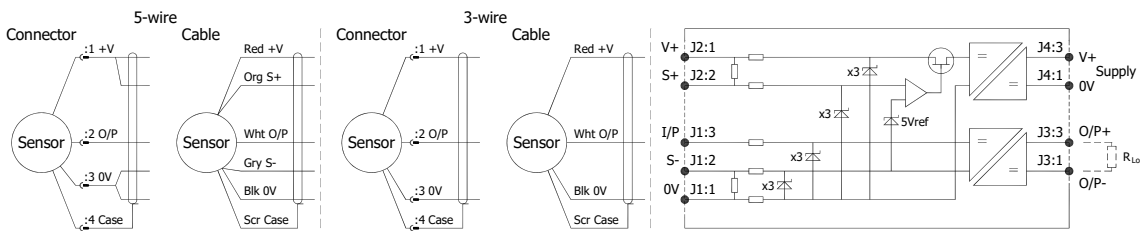

Cable Length (metres)	Up to 150	150 - 300	300 - 450	450 - 600	600 - 900	900 - 1000
Cross Section (mm <sup>2</sup> )	0.25	0.5	0.75	1.0	1.5	2.0

The table above shows recommended conductor sizes with respect to cable length for both three and five wire connections, based on copper conductors. Three wire connections will introduce a gain reduction of 5% and a ±1% temperature dependence of gain over the range -40°C to +80°C for the cable temperature. (i.e. about -150 ppm/°C for the maximum lengths shown and less pro rata for shorter lengths.)

It should be noted that the maximum cable length, as specified in the sensor certification, takes **precedence** and **must not** be exceeded.

Positek® sensors are supplied with three core 0.25 mm<sup>2</sup> cable as standard, however five core 0.25 mm<sup>2</sup> cable can be supplied on request. The galvanic isolation amplifier is available as;

G005-\*\*\* for 'G' and 'H' prefix sensors  
X005-\*\*\* for 'E', 'M' and 'X' prefix sensors

<sup>†</sup>  $R = \rho L/A$   $\rho$  is the resistivity of the conductor ( $\Omega m$ )  $L$  is the length of conductor (m)  $A$  is the conductor cross-sectional area (m<sup>2</sup>).

<sup>‡</sup> It is presumed that direct current flow is uniform across the cross-section of the wire, the galvanic isolation amplifier and sensor are a dc system.



# Generic Installation Information

## G SERIES SENSORS

INTRINSICALLY SAFE FOR HAZARDOUS GAS/VAPOUR ATMOSPHERES

CSA Qualified Intrinsically Safe Device Certificate number 13.2588225		Ex ia IIC T4 Ga Class I, Zone 0, AEx ia IIC T4 Ga Class I, Division 1, Groups A, B, C, D; T4 (Ta = -40°C to +80°C)	
Electronics Version	Output Description:	Supply Voltage: V <sub>s</sub> (tolerance)	Load resistance:
EX08	0.5 - 4.5V (ratiometric with supply)	+5V (4.5 - 5.5V) 10mA Nom.	5kΩ min

### Connector Pin Layout:

DIN 43650 C

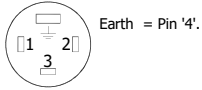

IEC 60947-5-2

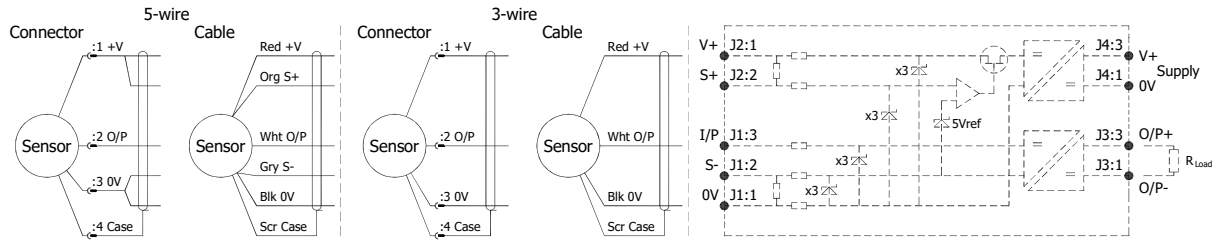

### Putting Into Service:

This sensor must only be installed, operated and maintained by competent and suitably trained personnel. The installation and maintenance must be carried out in accordance with all appropriate international, national and local standard codes of practice and site regulations for intrinsically safe apparatus. The use, installation, or maintenance of the sensor, in any other way than intended, may impair its operation or the protection it provides.

The sensor must be used with a galvanic isolation barrier designed to supply the sensor with a nominal 5V and to transmit the sensor output to a safe area. The barrier parameters must not exceed:-

$$\begin{aligned}
 U_i &= 11.4V & I_i &= 0.20A & P_i &= 0.51W \\
 C_i &= 1.36\mu F^* & L_i &= 860\mu H^* & & \text{(with maximum length integral cable)} \\
 C_i &= 1.16\mu F & L_i &= 50\mu H & & \text{(without integral cable)}
 \end{aligned}$$

\*Figures for 1km cable where:  $C_i = 200\text{pF/m}$  &  $L_i = 810\text{nH/m}$

Cable characteristics must not exceed:-

$$\begin{aligned}
 \text{Capacitance:} &\leq 200 \text{ pF/m or max. total of: } 200 \text{ nF} \\
 \text{Inductance:} &\leq 810 \text{ nH/m or max. total of: } 810 \mu\text{H}
 \end{aligned}$$

Approval only applies to specified ambient temperature range and atmospheric conditions in the range: 0.80 to 1.10 Bar, oxygen  $\leq 21\%$ .

### Markings and safety parameter information for product marked EX06, see annex 1.

#### Environmental Conditions

Pollution degree: 2

Installation category: I

Humidity 80% to temperatures up to 31 °C decreasing linearly to 50% rH at 40 °C; /// max 80% rh, non condensing.

The sensor has been assessed for indoor use only. Where used outdoors suitable environmental protection **must** be provided.

#### Special Condition for Safe Use:

The apparatus does not meet the 500 V r.m.s dielectric strength test between circuit and frame, in accordance with clause 6.3.13 of IEC 60079-11:2011. This must be taken into consideration on installation.

Under certain extreme circumstances, the non-metallic and isolated metal parts incorporated in the enclosure of this equipment may generate an ignition-capable level of electrostatic charge. Therefore the equipment shall not be installed in a location where the external conditions are conducive to the build-up of electrostatic charge on such surfaces. This is particularly important if the equipment is installed in a zone 0 location. In addition, the equipment shall only be cleaned with a damp cloth.

#### Use:

The sensor is designed to measure Linear or rotary displacement and provide a proportional analogue output signal.

P.T.O



For further information please contact:

[www.positek.com](http://www.positek.com) [sales@positek.com](mailto:sales@positek.com)

Tel: +44(0)1242 820027 fax: +44(0)1242 820615

Positek, Andoversford Industrial Estate, Cheltenham GL54 4LB. U.K.

G000-19c

1 of 2



# Generic Installation Information

## G SERIES SENSORS

INTRINSICALLY SAFE FOR HAZARDOUS GAS/VAPOUR ATMOSPHERES

### Assembly and Dismantling:

The unit is not to be serviced or dismantled and re-assembled by the user.

WARNING: Substitution of components may impair intrinsic safety,

AVERTISSEMENT: La substitution de composants peut altérer la sécurité intrinsèque.

### Maintenance:

No maintenance is required.

### Annex 1 - Markings and Entity Parameters for product with EX06 electronics system.

Ex ia IIC T4 (Ta= -40 to 80°C)

AEx ia IIC T4 (Ta= -40 to 80°C)

**Ui = 11.4V**

**Ii = 0.20A**

**Pi = 0.51W**

**Ci = 1.36µF\***

**Li = 710µH\***

(with maximum length integral cable)

**Ci = 1.16µF**

**Li = 50µH**

(without integral cable)

\*Figures for 1km cable where: Ci = 200pF/m & Li = 660nH/m

Cable characteristics must not exceed:-

Capacitance: ≤ 200 pF/m or max. total of: 200 nF

Inductance: ≤ 660 nH/m or max. total of: 660 µH



# Installation Information

## G125 350 BAR SUBMERSIBLE STAND-ALONE LINEAR POSITION SENSOR

### INTRINSICALLY SAFE FOR HAZARDOUS GAS/VAPOUR ATMOSPHERES

Connector Pin Layout:  
MC BH 4 M (face view)

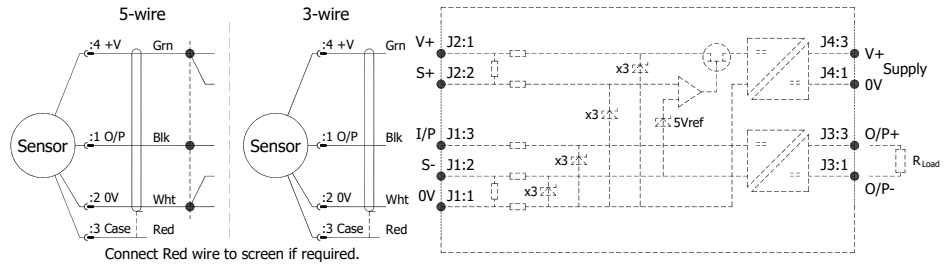

N.b. Cable free end must be appropriately terminated, including preventing water ingress into the cable.

<sup>†</sup>**Note!** See page 2 for connector handling instructions.

**Mechanical Mounting:** Depending on options; Body can be mounted by rod eye or by clamping the sensor body - body clamps are available, if not already ordered. Target by M8x1.25 male thread, rod eye or magnetic tip. It is assumed that the sensor and target mounting points share a common earth.

**Output Characteristic:** Target is extended 7 mm from end of body at start of normal travel. The output increases as the target extends from the sensor body, the calibrated stroke is between 5 mm and 800 mm.

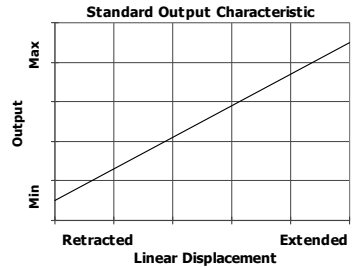

**Incorrect Connection Protection levels:-** The sensor is not protected against either reverse polarity or over-voltage. The risk of damage should be minimal where the supply current is limited to less than 50mA.





# Installation Information

## G125 350 BAR SUBMERSIBLE STAND-ALONE LINEAR POSITION SENSOR

### INTRINSICALLY SAFE FOR HAZARDOUS GAS/VAPOUR ATMOSPHERES

#### Connector Mating Instructions

##### Handling

- Always apply grease mating
- Disconnect by pulling straight, not at an angle
- Do not pull on the cable and avoid sharp bends at cable entry
- When using bulkhead connector, ensure that there are no angular load
- Do not over-tighten the bulkhead nuts
- Connectors should not be exposed to extended periods of heat or direct sunlight. If a connector becomes very dry, it should be soaked in fresh water before use

##### Cleaning

- General cleaning to remove any accumulated sand or mud on a connector should be performed using spray based contact cleaner (isopropyl alcohol)
- New grease must be applied again prior to mating

#### Greasing and mating above water (dry mate)

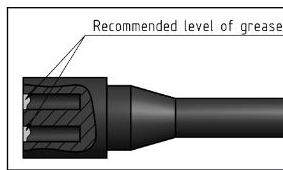

- Connectors must be greased with Molykote 44 Medium before every mating
- A layer of grease corresponding to approximately 1/10 of the socket depth should be applied to the female connector
- The inner edge of all the sockets should be completely covered, and a transparent layer of grease left visible on the face of the connector
- After greasing, fully mate the male and female connector in order to secure optimal distribution of grease on pins and in sockets
- To confirm that the grease has been sufficiently applied, demate and check for grease on every male pin. Then re-mate the connector

#### Greasing and mating under water (wet mate)

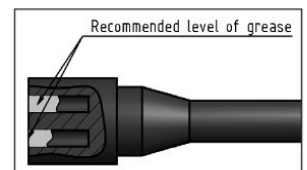

- Connectors must be greased with Molykote 44 Medium before every mating
- A layer of grease corresponding to approximately 1/3 of the socket depth should be applied to the female connector
- All sockets should be completely sealed, and a transparent layer of grease left visible on the face of the connector
- After greasing, fully mate the male and female connector and remove any excess grease from the connector joint